

**Egzamin z Mechaniki Konstrukcji, 10.09.2015**  
**Exam on the Mechanics of Structures**

NAZWISKO, Imię LAST NAME, First Name				
ocena zadania 1	ocena zadania 2	ocena zadania 3	ocena egzaminu	ocena łączna

**Zadanie 1 (Rys. 1) Problem #1 (Fig. 1)**

Oblicz reakcję  $V_A$  korzystając z tw. Bettiego.  
 Calculate reaction  $V_A$  by the Betti Theorem.

**Zadanie 2 (Rys. 1) Problem #2 (Fig. 1)**

Oblicz reakcję  $V_A$  stosując Metodę Przemieszczeń bezpośrednio do układu z Rys. 1.  
 Calculate reaction  $V_A$  by applying the Displacement Method directly to the structure in Fig. 1.

**Zadanie 3 (Rys. 2) Problem #3 (Fig. 2)**

Oblicz wartość  $k$ , dla której wartość kąta  $\varphi_B = 0$ .  
 Następnie oblicz  $V_A$  oraz  $V_D$ .  
 Calculate the value of  $k$  for which  $\varphi_B = 0$ .  
 Next, calculate  $V_A$  and  $V_D$ .

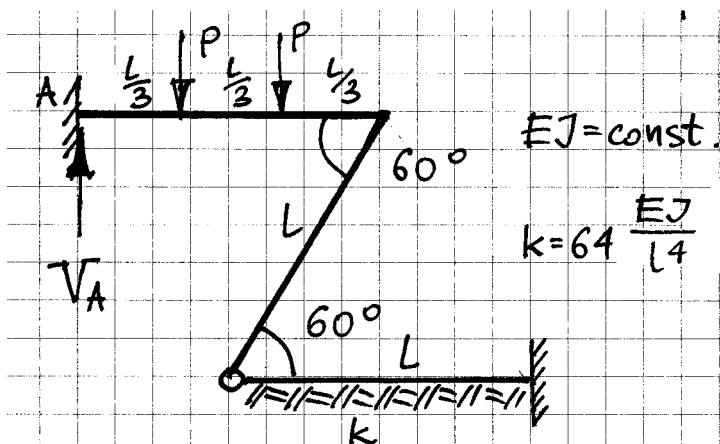

Rys. 1 (Fig. 1)

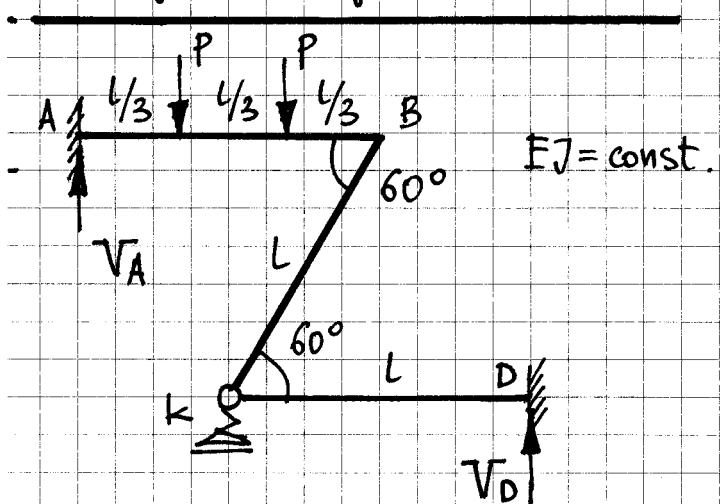

Rys. 2 (Fig. 2)

$\lambda$	$C(\lambda)$	$S(\lambda)$	$T(\lambda)$	$R(\lambda)$	$M(\lambda)$	$N(\lambda)$	$C'(\lambda)$	$T'(\lambda)$	$R'(\lambda)$
0,0	4,000	2,000	6,000	6,000	12,000	12,000	3,000	3,000	3,000
0,1	4,000	2,000	6,000	6,000	12,000	12,000	3,000	3,000	3,000
0,2	4,000	2,000	6,000	6,000	12,002	11,999	3,000	3,001	3,000
0,3	4,000	2,000	6,002	5,999	12,012	11,996	3,001	3,003	2,999
0,4	4,001	1,999	6,005	5,997	12,038	11,987	3,002	3,009	2,996
0,5	4,002	1,998	6,013	5,992	12,093	11,968	3,005	3,021	2,990
0,6	4,005	1,996	6,027	5,984	12,192	11,933	3,010	3,044	2,980
0,7	4,009	1,993	6,050	5,970	12,356	11,877	3,018	3,082	2,962
0,8	4,016	1,988	6,086	5,949	12,608	11,790	3,031	3,140	2,936
0,9	4,025	1,981	6,137	5,919	12,972	11,665	3,050	3,223	2,898
1,0	4,038	1,972	6,208	5,877	13,480	11,491	3,075	3,338	2,846
1,1	4,055	1,959	6,304	5,821	14,163	11,258	3,109	3,492	2,776
1,2	4,078	1,942	6,429	5,748	15,056	10,956	3,153	3,692	2,687
1,3	4,107	1,920	6,589	5,656	16,197	10,573	3,209	3,944	2,575
1,4	4,143	1,894	6,787	5,541	17,624	10,100	3,277	4,254	2,438
1,5	4,186	1,862	7,030	5,402	19,377	9,526	3,359	4,629	2,275
1,6	4,239	1,823	7,323	5,236	21,498	8,844	3,455	5,071	2,086
1,7	4,301	1,778	7,670	5,041	24,026	8,049	3,566	5,586	1,871
1,8	4,373	1,726	8,075	4,818	27,000	7,136	3,693	6,174	1,632
1,9	4,456	1,666	8,541	4,564	30,459	6,106	3,833	6,835	1,370
2,0	4,550	1,600	9,073	4,280	34,438	4,962	3,988	7,568	1,091

$\lambda$	$M'(\lambda)$	$N'(\lambda)$	$L'(\lambda)$	$C''(\lambda)$	$T''(\lambda)$	$M''(\lambda)$	$M'''(\lambda)$	$N'''(\lambda)$
<b>0,0</b>	<b>3,000</b>	<b>3,000</b>	<b>3,000</b>	<b>0,000</b>	<b>0,000</b>	<b>0,000</b>	<b>0,000</b>	<b>0,000</b>
0,1	3,000	3,000	3,000	0,000	0,000	0,000	0,000	0,000
0,2	3,003	2,999	3,002	0,002	0,003	0,006	0,002	-0,001
0,3	3,016	2,995	3,008	0,011	0,016	0,032	0,011	-0,005
0,4	3,050	2,986	3,024	0,034	0,051	0,102	0,034	-0,017
<b>0,5</b>	<b>3,121</b>	<b>2,965</b>	<b>3,059</b>	<b>0,082</b>	<b>0,123</b>	<b>0,247</b>	<b>0,083</b>	<b>-0,042</b>
0,6	3,251	2,928	3,122	0,166	0,250	0,505	0,172	-0,086
0,7	3,465	2,867	3,226	0,298	0,449	0,918	0,318	-0,158
0,8	3,793	2,774	3,385	0,484	0,734	1,520	0,541	-0,268
0,9	4,267	2,639	3,615	0,726	1,107	2,340	0,861	-0,424
<b>1,0</b>	<b>4,925</b>	<b>2,454</b>	<b>3,934</b>	<b>1,017</b>	<b>1,563</b>	<b>3,394</b>	<b>1,301</b>	<b>-0,635</b>
1,1	5,807	2,209	4,363	1,342	2,087	4,688	1,884	-0,910
1,2	6,954	1,893	4,920	1,686	2,658	6,225	2,630	-1,253
1,3	8,408	1,500	5,626	2,031	3,258	8,008	3,560	-1,665
1,4	10,213	1,021	6,503	2,363	3,871	10,052	4,689	-2,144
<b>1,5</b>	<b>12,408</b>	<b>0,455</b>	<b>7,571</b>	<b>2,675</b>	<b>4,492</b>	<b>12,380</b>	<b>6,029</b>	<b>-2,681</b>
1,6	15,031	-0,200	8,847	2,963	5,119	15,027	7,587	-3,263
1,7	18,117	-0,941	10,350	3,228	5,756	18,031	9,368	-3,872
1,8	21,694	-1,759	12,093	3,472	6,411	21,438	11,372	-4,487
1,9	25,786	-2,642	14,088	3,700	7,092	25,290	13,599	-5,085
<b>2,0</b>	<b>30,412</b>	<b>-3,573</b>	<b>16,347</b>	<b>3,915</b>	<b>7,807</b>	<b>29,631</b>	<b>16,049</b>	<b>-5,642</b>

$\lambda = l \sqrt{\frac{k}{4EJ}}$

$\Phi_i = \frac{EJ}{l} \left[ C(\lambda)\phi_i + S(\lambda)\phi_k + T(\lambda)\frac{w_i}{l} - R(\lambda)\frac{w_k}{l} \right] - \gamma(\lambda)pl^2$	$\Phi_i = \frac{EJ}{l} \left[ C''(\lambda)\phi_i + T''(\lambda)\frac{w_i}{l} \right]$
$\Phi_k = \frac{EJ}{l} \left[ S(\lambda)\phi_i + C(\lambda)\phi_k + R(\lambda)\frac{w_i}{l} - T(\lambda)\frac{w_k}{l} \right] + \gamma(\lambda)pl^2$	$W_i = \frac{EJ}{l^2} \left[ T''(\lambda)\phi_i + M''(\lambda) \right]$
$W_i = \frac{EJ}{l^2} \left[ T(\lambda)\phi_i + R(\lambda)\phi_k + M(\lambda)\frac{w_i}{l} - N(\lambda)\frac{w_k}{l} \right] - \gamma_T(\lambda)pl$	$W_k = -\frac{EJ}{l^2} \left[ R(\lambda)\phi_i + T(\lambda)\phi_k + N(\lambda)\frac{w_i}{l} - M(\lambda)\frac{w_k}{l} \right] - \gamma_T(\lambda)pl$
$\Phi_i = \frac{EJ}{l} \left[ C'(\lambda)\phi_i + T'(\lambda)\frac{w_i}{l} - R'(\lambda)\frac{w_k}{l} \right]$	$\Phi_i = \frac{EJ}{l} \left[ C''(\lambda)\phi_k - T''(\lambda)\frac{w_k}{l} \right]$
$W_i = \frac{EJ}{l^2} \left[ T'(\lambda)\phi_i + M'(\lambda)\frac{w_i}{l} - N'(\lambda)\frac{w_k}{l} \right]$	$W_k = -\frac{EJ}{l^2} \left[ T''(\lambda)\phi_k - M''(\lambda)\frac{w_k}{l} \right]$
$W_k = -\frac{EJ}{l^2} \left[ R'(\lambda)\phi_i + N'(\lambda)\frac{w_i}{l} - L'(\lambda)\frac{w_k}{l} \right]$	
$\Phi_k = \frac{EJ}{l} \left[ C'(\lambda)\phi_k + R'(\lambda)\frac{w_i}{l} - T'(\lambda)\frac{w_k}{l} \right]$	$W_i = \frac{EJ}{l^2} \left[ M'''(\lambda)\frac{w_i}{l} - N'''(\lambda)\frac{w_k}{l} \right]$
$W_i = \frac{EJ}{l^2} \left[ R'(\lambda)\phi_k + L'(\lambda)\frac{w_i}{l} - N'(\lambda)\frac{w_k}{l} \right]$	$W_k = -\frac{EJ}{l^2} \left[ N'''(\lambda)\frac{w_i}{l} - M'''(\lambda)\frac{w_k}{l} \right]$
$W_k = -\frac{EJ}{l^2} \left[ T'(\lambda)\phi_k + N'(\lambda)\frac{w_i}{l} - M'(\lambda)\frac{w_k}{l} \right]$	

Egzamin z MK IPB, 10.09.2015, zadanie 1

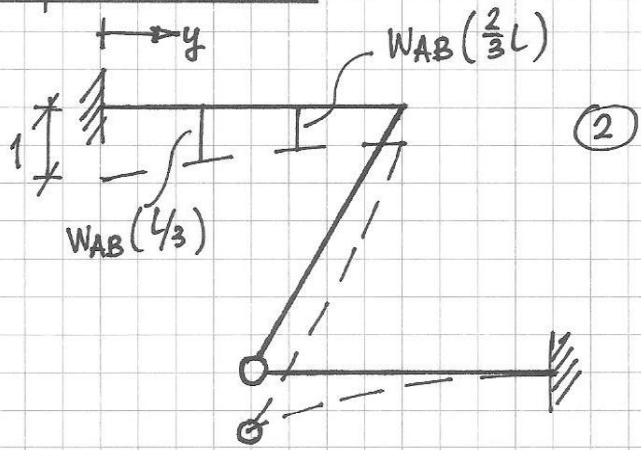
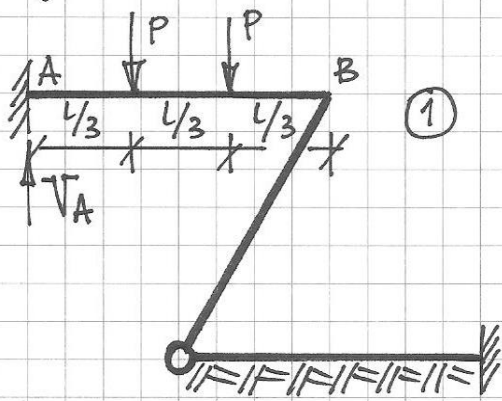

$$L_{12} = L_{21} \Rightarrow -V_A \cdot 1 + P \cdot W_{AB}(\frac{1}{3}L) + P \cdot W_{AB}(\frac{2}{3}L) = 0$$

opracował: G. Dziubanowski

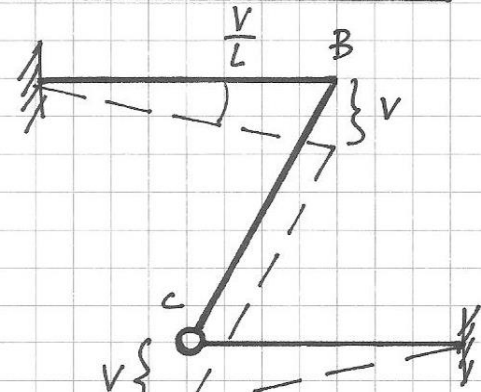
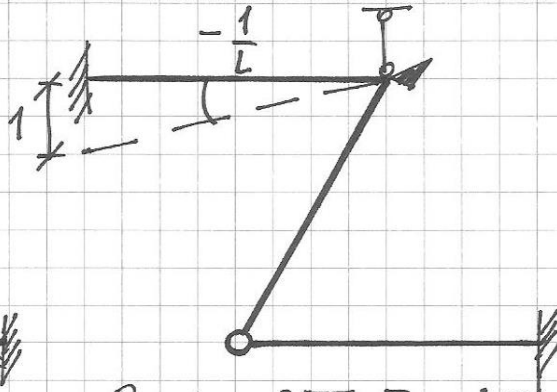
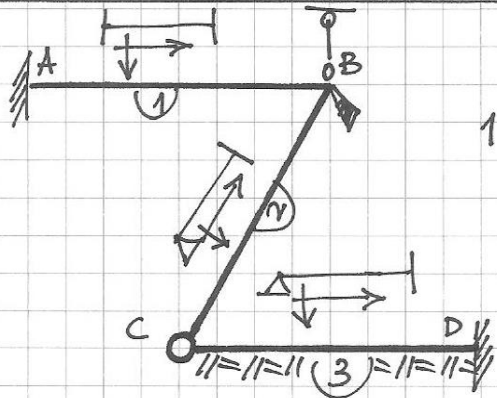

$$q = \begin{bmatrix} \varphi_B \\ \frac{V}{L} \end{bmatrix}$$

$$\lambda = 2$$

$$\Phi_B^{(1)} = \frac{2EJ}{L} \left[ 3 \cdot \frac{1}{L} \right]$$

$$W_B^{(1)} = -\frac{6EJ}{L^2} \left[ 2 \cdot \frac{1}{L} \right]$$



$$\begin{cases} \Phi_B^{(1)} + \Phi_B^{(2)} = 0 \\ W_B^{(1)} \cdot \bar{v} + W_C^{(3)} \cdot \bar{v} + W_B^{(2)} \cdot \frac{1}{2} \bar{v} + W_C^{(2)} \cdot \frac{1}{2} \bar{v} = 0 \end{cases}$$

$$\Phi_B^{(1)} = \frac{2EJ}{L} \left[ 2\varphi_B - 3 \frac{V}{L} \right] + \Phi_B^{(1)}$$

$$\Phi_B^{(2)} = \frac{3EJ}{L} [\varphi_B]$$

$$W_B^{(1)} = -\frac{6EJ}{L^2} \left[ \varphi_B - 2 \frac{V}{L} \right] + W_B^{(1)}$$

$$W_B^{(2)} = -W_C^{(2)} = \frac{3EJ}{L^2} [\varphi_B]$$

$$W_C^{(3)} = \frac{EJ}{L^2} \left[ L'(2) \frac{V}{L} \right]$$

$$W_{AB}(y) = C_0 + C_1 y + C_2 y^2 + C_3 y^3$$

$$W_{AB}(0) = 1$$

$$W'_{AB}(0) = 0$$

$$W_{AB}(L) = 0,295$$

$$W'_{AB}(L) = -0,603 \cdot \frac{1}{L}$$

$$\varphi_B = -0,603 \cdot \frac{1}{L}$$

$$\frac{V}{L} = 0,295 \cdot \frac{1}{L}$$

$$W_{AB}(y) = 1 - 1,512 \frac{y^2}{L^2} + 0,807 \frac{y^3}{L^3}$$

$$V_A = P \cdot W_{AB}(\frac{1}{3}L) + P \cdot W_{AB}(\frac{2}{3}L) = 1,429P$$



Egzamin MK IPB, 10.09.2015, zadanie 2

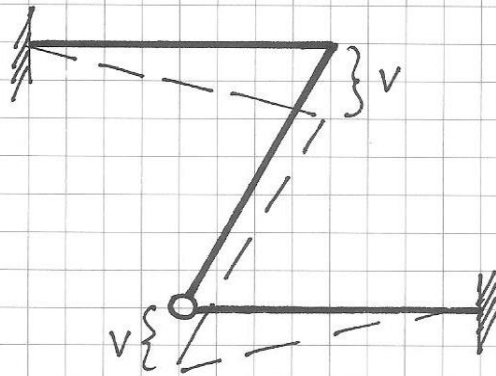
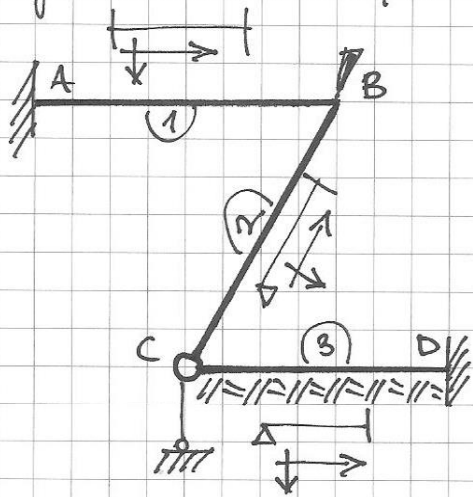

$$q = [\varphi_B \quad \frac{v}{L}]^T \quad \lambda = 2$$

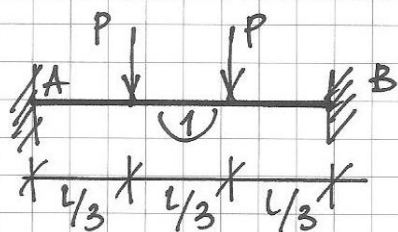

$$\Phi_A^{(1)} = -\frac{2}{9} PL$$

$$\Phi_B^{(1)} = \frac{2}{9} PL$$

$$W_A^{(1)} = -P$$

$$W_B^{(1)} = -P$$

$$\begin{cases} \Phi_B^{(1)} + \Phi_B^{(2)} = 0 \\ W_B^{(1)} \cdot \bar{v} + W_C^{(3)} \cdot \bar{v} = 0 \end{cases}$$

Suma prac sił  $W_B^{(2)}$ ,  $W_C^{(2)}$  jest równa 0, patrz zadanie 1.

$$\Phi_B^{(1)} = \frac{2EJ}{L} [2\varphi_B - 3\frac{v}{L}] + \frac{2}{9} PL$$

$$\Phi_B^{(2)} = \frac{3EJ}{L} [\varphi_B]$$

$$W_B^{(1)} = -\frac{6EJ}{L^2} [\varphi_B - 2\frac{v}{L}] - P$$

$$W_C^{(3)} = \frac{EJ}{L^2} [L(2)\frac{v}{L}]$$

$$\varphi_B = -0,002 \frac{PL^2}{EJ}$$

$$\frac{v}{L} = 0,035 \frac{PL^2}{EJ}$$

$$T_A = -W_A^{(1)} = \frac{6EJ}{L^2} [\varphi_B - 2\frac{v}{L}] + P = 1,429 P$$

opracował: G. Dzierżanowski